

innovations

Technics – Markets – Trends

Volume 4 – 4/2010

*A box
full of
innovations*



↑ SURPRISE INSIDE ↑



PRIORITY
PRIORITAIRE



10 A04

Booth

16 D22



Articles that appeared in *WITTMANN innovations* so far

Conveying/Drying

- Central drying and conveying at Robert BOSCH 1/2007
- Quality control of the WITTMANN dryers 1/2007
- Drying and conveying system at Kromberg & Schubert 2/2007
- Cost efficient material drying 2/2007
- FEEDMAX conveying units fit for the clean room 3/2007
- The new DRYMAX ED80 material dryer 3/2007
- Conveying: Focus on material feeding 1/2008
- The WITTMANN network control at Arge2000 2/2008
- Changing parameters when conveying different materials 2/2008
- Optimizing a material conveying system 3/2008
- DRYMAX dryers complete with energy rating 3/2008
- Metchem central material handling system 4/2008
- Auxiliaries at Delphi in China 1/2009
- The LISI COSMETICS central system 2/2009
- Perfect planning of central systems avoids downtime 3/2009
- Testing the WITTMANN energy claims at FKT 4/2009
- The new FEEDMAX B 100 1/2010
- Greiner is saving energy by using WITTMANN dryers 2/2010
- The A.C.S. conveying system 3/2010

Blending

- The new WITTMANN blenders of the GRAVIMAX series 2/2007
- The truth about blender economics 3/2007
- The new GRAVIMAX 14V blender 3/2009



WITTMANN innovations (Volume 4 - 4/2010)

Quarterly magazine of WITTMANN Kunststoffgeräte GmbH and WITTMANN BATTENFELD GmbH. Appears to meet the informational demands of staff and customers. Editorial office: WITTMANN Kunststoffgeräte GmbH, Lichtblaustraße 10, 1220 Vienna; tel. +43-1 250 39-204, fax +43-1 250 39-439; bernhard.grabner@wittmann-group.com; <http://www.wittmann-group.com>
Issue 1/2011 of "WITTMANN innovations" will appear at the beginning of the first quarter 2011.

In-Mold Labeling

- WITTMANN IML stack mold systems 3/2007
- The WITTMANN 2 + 2 stack mold 1/2008
- ATM d.o.o. in Serbia grows with WITTMANN systems 3/2009

Temperature Control

- The advantages of pulsed cooling 1/2007
- Comparing water to oil 2/2007
- The new temperature controllers of the TEMPRO plus C series 3/2007
- The new COOLMAX compact cooling units 2/2008
- Temperature controller "guarding" injection molding machines 3/2008
- Temperature controllers with DUO cooling 4/2008
- Variothermal tempering 1/2009
- The new TEMPRO plus C180 2/2009
- The new TEMPRO direct C120 [C250] 3/2009
- WFC: WITTMANN Water Flow Control functionality 4/2009
- TEMPRO plus C180 water temperature controller 1/2010
- WITTMANN TEMPRO: The universal benchmark 2/2010
- BFMOLD™ mold cooling system 3/2010

Injection Molding

- WITTMANN BATTENFELD: One stop shopping for injection molding 4/2008
- Metal injection molding at Indo-US MIM 4/2008
- Cost optimization: EcoPower by BATTENFELD 1/2009
- IT assisted services 1/2009
- Water injection for all-plastic parts 2/2009
- Krona Indústria and WITTMANN BATTENFELD 2/2009
- Molding micro-parts with the Microsystem 50 3/2009
- Multi-component process at wolfcraft 4/2009
- Process data acquisition: partnership with Wille System 4/2009
- The new all-electric EcoPower injection molding machine 4/2009
- Thomas Dudley and WITTMANN BATTENFELD 1/2010
- IML with TM Xpress 1/2010
- AIRMOULD® and AQUAMOULD® Mobile 1/2010
- Design Molded Plastics and their molding machines 2/2010
- Stadelmann relies on Wille and WITTMANN BATTENFELD 2/2010
- The new MicroPower molding machine 3/2010
- AQUAMOULD® and projectile injection technology 3/2010

Automation

- Production and quality control in medical engineering 1/2007
- The handling of large structural foam parts 2/2007
- The new R8 robot control 3/2007
- High-end: The production of seat adjustment rods 1/2008
- Drive engineering for robots 1/2008
- Automating the production of transponder pins 2/2008
- Automated production of remote control keys 3/2008
- Automation at Carclo Technical Plastics, UK 4/2008
- The flexible automation cell as ABA-PGT 1/2009
- The cultivation of growth with WITTMANN robots 2/2009
- Bruder toy wheel production 4/2009
- Production of pallets at Georg Utz in Poland 1/2010
- EcoMode helps getting energy efficient robots 2/2010
- Automated production of oil level sensors 2/2010
- Automating rotation welding 3/2010

Granulation

- Inline recycling of sprues 1/2007
- Giant granulator MCP 100 2/2007
- The new MAS granulator 3/2007
- The challenging recycling process 1/2008
- The MC 70-80 granulator at Centrex 2/2008
- Gibo Plast enforces recycling 2/2009
- The new AF auger feed for MC central granulators 4/2009
- Grinding of ferrite 1/2010
- Grinding critical material 3/2010

News From The Subsidiaries

- Australia 2/2008
- Austria 2/2008, 3/2008, 1/2010
- Benelux 3/2008, 2/2009
- Brazil 3/2007, 1/2009
- Bulgaria 2/2009
- Canada 1/2007, 1/2008, 2/2008, 3/2009
- China 2/2010
- Czech Republic/Slovakia 4/2009
- Denmark 1/2009
- Finland 4/2008
- France 2/2007, 3/2008
- Germany 1/2007
- Great Britain 2/2009, 2/2010
- Hungary 1/2008
- India 2/2008, 3/2010
- Italy 4/2008, 1/2010
- Mexico 3/2007, 3/2009
- Slovenia/Croatia 1/2010
- Southeast Asia 2/2007
- South Korea 3/2010
- Spain 3/2007
- Sweden 2/2009
- Switzerland 1/2008
- Taiwan 4/2009
- Turkey 3/2008
- USA 2/2008, 3/2009

Editorial



Michael Wittmann

Dear Reader,

“Lights, camera, action!” for the world’s biggest event for the plastics and rubber industry, the K 2010. From Oct. 27th to Nov. 3rd around 3,000 exhibitors will display in Düsseldorf their latest developments for the plastics market. Naturally, we are prominently represented on almost 1,200 m² (13,000 ft²) with our two big product areas: WITT-MANN in hall 10/A04 and WITTMANN BATTENFELD in hall 16/D22. With over 125 products, amongst them 15 completely new releases – the result of many years of development – we are presenting indeed a fireworks display of innovations. Our show slogan “A box full of innovations” should demonstrate our relentless urge to innovation.

All new developments in our “box of innovations” are oriented along the current requirements of the plastic processing industry. Requirements, which were important all along, but became even more important during the recession year 2009: i.e. optimum energy efficiency, therefore competitiveness coupled with the highest user friendliness for best use. The results of our persistent development work present themselves under the product and process terms *EcoPower*, *EcoMode*, *SmartReg*, *SmartFlow*, *ServoMotion*, *3-Save* and many more – designations for our innovative and superior patented solutions.

Our show news stems from all product fields. Amongst them are four new injection molding machine models of the *PowerSeries* as well as four new robot models, two completely new temperature controllers, two equally revolutionary dryers and one new granulator. In addition, we will introduce several new application technologies. We want to deliver this issue of *innovations* to you as an introductory guide for your visit to our K show booths. There you will gain a detailed view on our products. Considering the multitude of news is not an easy task, but our entire international sales and technical support team is available to answer any questions. In this issue, we are pleased to present this team to you.

The normally positive mood before the show is further elevated through the extraordinary growth in our industry. Especially the capital investment sector celebrates a rapid resurgence, almost reaching the levels of 2007 and 2008 and in some sectors even higher. In June 2010, we were able to celebrate our best bookings month in our history. That the months of July and August however did not show any signs of weakness, despite the vacation season, caught us by surprise.

In any case, we wish you an enjoyable reading experience with this issue of *innovations* and are looking forward to a personal meeting at the K 2010 in Düsseldorf.

Sincerley, Michael Wittmann

Content

Injection Molding

The MacroPower machine



Gabriele Hopf the new large machine from BATTENFELD, **Page 4, ...**

Mission: medical application



... and about the collaboration with STELLA Kunststofftechnik GmbH, Germany, **Page 6.**

Automation

The new R8.2 robot control



Martin Stammhammer presents the functions of the new control generation. **Page 8**

Temperature Control

New TEMPRO with touch screen



Gerald Schodl introduces the new temperature controller and its functions. **Page 10**

IML

Canadian container production



Jérôme Empereur describes the IML application running at PLASTIPAK Inc., Canada. **Page 12**

Conveying

FEEDMAX Primus has arrived!



Markus Wolfram about the new series of WITTMANN conveying units. **Page 14**

In place of a branch portrait:
The international WITTMANN Group Sales Team at K 2010.
(p. 15)



The MacroPower – The new benchmark in large machines

With its new MacroPower injection molding machine, introduced in the 800 t clamping force version at the Competence Days of the WITTMANN group on 28th and 29th April 2010 in Kottlingbrunn, WITTMANN BATTENFELD has achieved a successful comeback to large machine manufacturing. At the K 2010 in Düsseldorf, the 1,000 t version, another model from this series, will now be presented.

Gabriele Hopf

Large machine manufacturing has a long tradition at WITTMANN BATTENFELD. Ever since the foundation of BATTENFELD Spritzgießtechnik in 1948, large machines have been a major concern in the company's product development. BATTENFELD was regarded as a pioneer in this field and attained market leadership within a short time. In 1991, BATTENFELD put the largest injection molding machine worldwide with 8,000 t clamping force on the market. The concentration of production at the Kottlingbrunn facility brought about a shift in product portfolio to machines in the clamping force range from 5 t to a maximum of 650 t. With the new *MacroPower* series, WITTMANN BATTENFELD has now extended its range in a first step to include 800 and 1,000 t models and thus achieved a successful comeback to large machine manufacturing. Besides the *EcoPower* and the *MicroPower*, the *MacroPower* represents the third machine series of the new *PowerSeries* range.

The *MacroPower* is causing a stir on the market for large injection molding machines with its outstanding features derived from WITTMANN BATTENFELD's many years of experience. On the whole, the *PowerSeries* demonstrates once again the company's innovative strength and its consistent orientation towards maximum customer benefit.

Compact, fast, precise, clean

The new *MacroPower* distinguishes itself by its extremely compact design, high speed, precision and cleanliness. A unique feature in its size group is the machine's minimal length and footprint. The compactness of the *MacroPower*, greatly appreciated by users, is the result of combining a

new 2-platen clamping system with the well-known, compact injection units from the WITTMANN BATTENFELD HM series. The optional integration of WITTMANN robots in the machine frame leads to a further reduction in space requirements – with a simultaneous improvement in energy efficiency.

The *MacroPower* is equipped with an innovative, patented locking system which enables extremely short locking times. This, together with its high movement speeds, makes

The new MacroPower injection molding machine from WITTMANN BATTENFELD.

Schematic diagram of mold insertion in the standard version.

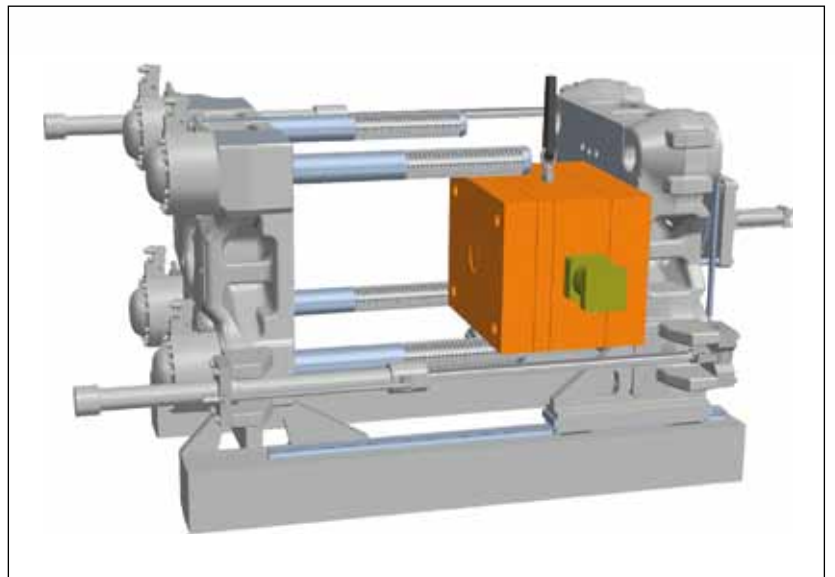

the machine extremely fast. This 2-platen machine is clean, primarily due to the linear guides of its moving platen, which make it possible to dispense with the oil pan normally required to lubricate the sliding elements. The linear guides of the moving platen are also the key to ultimate precision, since they ensure precise platen parallelism across the entire stroke. Thanks to low dynamic friction, the *MacroPower's* mold protection system is extremely sensitive, and the smooth running of the guides also contributes to energy efficiency.

Easy mold insertion

The locking system integrated in the moving platen enables a machine design with tie-bars of below-average length. In conjunction with an extended

FELD tie-bar pulling device is available as an equipment option; it retracts (or pulls out) tie-bars at the push of a button and thus easily provides the necessary free space up to maximum mold height.

Intelligent drive concept

The *MacroPower* is powered by a three-phase motor with electrically adjustable delivery pumps, with a modular concept being applied in three extension stages with parallel functions, which enables a substantial reduction in cycle times. A speed-controlled servo drive with a constant pump is also available as an option for further reduction of energy consumption as well as noise level, which is already low, thanks to a sound-insulated pump compartment.

One machine, many options

For maximum user benefit, the *MacroPower* comes with a modular design and preconfigured. A great variety of extension options are available, depending on individual requirements. The machine system consists of a basic platform that can be supplemented with comprehensive extension packages according to special needs, such as multi-component technology applications.

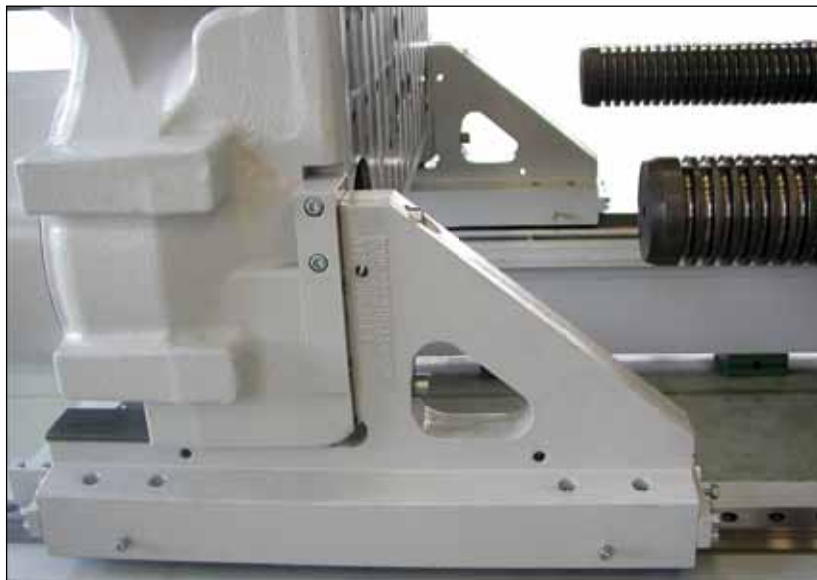
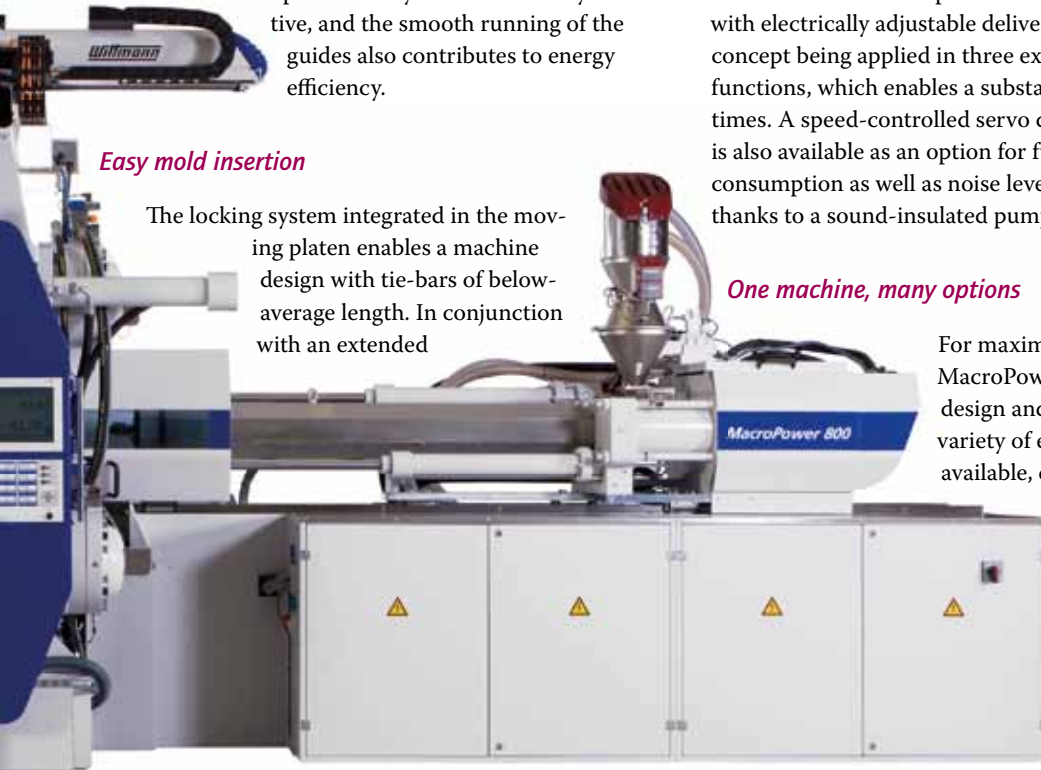

UNILOG B6 – One control system for all machines

The *MacroPower* is also equipped with the UNILOG B6 control system. This control system, operating under Windows XP™, makes the integration of the machine in PDA systems (and above all Internet-based service support) extremely easy. The operation of the injection molding machine, robots and all integrated peripheral equipment takes place via the machine screen, which makes it extremely simple to understand and easy to learn within a short time.

The MacroPower's linear guides.

safety gate stroke at the rear, this makes it possible to insert molds laterally from the rear without having to pull out a tie-bar for lateral loading.

With this method of loading, extremely large molds can also be inserted in several parts. This not only facilitates mold insertion considerably, but also reduces the cost, since an additional tie-bar pulling device can now be dispensed with in most cases; moreover, low ceilings in halls no longer present any problems. The patented WITTMANN BATTEN-

The new MacroPower at K 2010

The *MacroPower* with 800 t clamping force, presented for the first time at the Competence Days of the WITTMANN group this year, was enthusiastically welcomed by trade visitors.

From October 27th to November 3rd, the latest model of this injection molding machine, now extended to 1,000 t, will also be on display for the first time at the K 2010 in Düsseldorf. ♦

STELLA relies on WITTMANN BATTENFELD

In April of this year, the first machine of the new EcoPower series was installed at STELLA Kunststofftechnik GmbH – one of the most important partners for the production of liquid pharmaceuticals. The long-standing WITTMANN BATTENFELD customer based in Eltville, Germany, specializes in products for packaging, dosing and administration of drugs in liquid form. STELLA has relied on cooperation with WITTMANN BATTENFELD for many years.

Gabriele Hopf



More than 40 WITTMANN BATTENFELD injection molding machines are in operation at STELLA's Kastellaun plant.

STELLA, a family-owned company in the second generation, developed from a glass foundry in Thuringia, which in the last century used to produce the bottles known as “Stern” (= star) dripper bottles that gave today’s STELLA Kunststofftechnik GmbH its name. Since its foundation in 1949, this company has been engaged in developing, manufacturing and distributing packaging products made of glass and plastics. Its product portfolio includes injection-molded plastic parts in the form of dripper inserts, spouts, syringe adapters, dosing pipette adapters, screw caps, screw caps with originality ring, pipettes and pipette caps, pistons, sealing elements and cylinders of dosing pipettes, dosing cups, components of childproof closures and tube bodies.

STELLA now counts pharmaceutical companies of all sizes in more than 70 countries among its customers, which invariably place the most stringent demands on parts quality. Only such materials and colorants as have been approved for direct contact with pharmaceuticals and food are processed.

Today, STELLA employs 85 people at two facilities in Germany, in Eltville (since 1965) and Kastellaun (since 1978). With some 650 million parts manufactured annually – the equivalent of about 900 million to 1 billion individual value-adding processes – STELLA undertakes mass production of parts with a typical part weight of around two grams.

Heino Deussen, owner-manager of STELLA, and Georg Fischer, plant manager in Kastellaun, point to the high significance of technical precision and the virtual absence of germs in the production of their parts. “Our customers’ fault tolerance is minimal. The slightest deficiencies or contamination of products would have serious consequences, including return shipments of entire production lots and claims for damages.”

Thanks to the use of latest technology, STELLA meets these demands in every respect. The finished parts are “collected” from the processing machines and transferred to quality inspection by a driverless box transport system, without coming into contact with humans. STELLA has its own mold design and mold-making facilities with appro-

appropriate clean-room technology and uses tools for industrial image processing as well as modern labeling and assembly processes.

STELLA and WITTMANN BATTENFELD

STELLA and WITTMANN BATTENFELD can look back on many years of partnership. The first BATTENFELD injection molding machine was installed at STELLA in 1986. Today, 40 injection molding machines are operating at the Kastellaun plant, and two more in Eltville, all of which have been supplied by WITTMANN BATTENFELD. The two



machines delivered most recently already came equipped with integrated WITTMANN robots with a UHS (Ultra High Speed) system, which is an additional benefit. After all, the company has been cooperating successfully with WITTMANN Robot Systeme GmbH for many years as well. Most of its machines are hydraulic machines from the CDC and HM series. In April 2010, the first all-electric machine

was installed, a WITTMANN BATTENFELD *EcoPower* 110, also with an integrated WITTMANN robot. The *EcoPower*, with its outstanding clean room compatibility, high precision and process reliability, meets the high quality standards in medical technology production in every respect. Last but not least, it offers the benefit of low energy consumption.

Heino Deussen: "With our injection molding machines, we make use of all options that WITTMANN BATTENFELD offers in order to ensure highest precision, repeatability and clean room compatibility. Here, the *EcoPower* meets our demands in a special way." Georg Fischer regards above all the absence of hydraulics and lube oil as a great advantage. The high energy-efficiency of the *EcoPower* is seen as a feature which will become more and more significant. Rising energy costs, Deussen says, are a given, and highly automated production like that of STELLA requires a large amount of energy. Passing on rising energy costs to customers is regarded as an unrealistic approach. For these reasons, the development of the WITTMANN BATTENFELD *EcoPower* seems to point in the right direction.

Apart from the excellent cost/benefit ratio of the machines, STELLA specially appreciates the quality of the partnership. Heino Deussen: "The cooperation based on mutual trust and WITTMANN BATTENFELD's readiness to cater to its customers' wishes, particularly in terms of configuration options and special equipment, is extremely valuable to us." Georg Fischer appreciates the uncomplicated processing of transactions in the business relations with WITTMANN BATTENFELD. From STELLA's point of view, the homogeneous machinery on its production floor has proved its worth in every respect over the decades.

EcoPower – precise, clean and energy-efficient

With the new, all-electric *EcoPower*, STELLA now has an injection molding machine that offers the ultimate in efficiency, precision and cleanliness. It features a compact injection unit and a clean clamping unit with a highly efficient direct drive. The waste heat, which is normally not utilized, and the braking energy of the drives, usually reclaimed by an elaborate system, are fully utilized within the machine in the *EcoPower* series, to supply the control system with the necessary voltage and for barrel heating. This makes the machine series extremely energy-efficient.

The injection unit is laid out for high injection speeds of up to 400 mm/s. The direct drive via a circulating ball spindle minimizes transmission loss and favors precise regulation and repeatability of metering and injection processes. This ensures a high degree of process reliability. The efficient, precise drive of the toggle on the clamping unit features high dynamics, positioning accuracy and, once again, energy-efficiency. The exclusive use of direct drives dispenses with the particle emissions that are inevitable with belt drives and sliding guides. Since the toggle bolts are encapsulated, no oil contamination can occur on the clamping unit either. Thanks to its modular concept, the standard version of the machine can be configured for a great variety of applications with short delivery times, for example for high-speed applications or – the NUMBER ONE priority for STELLA – for high-precision injection molding under clean room conditions. ♦

Heino Deussen, owner-manager of STELLA Kunststofftechnik GmbH, with Bernd Wedler of WITTMANN BATTENFELD.

Driverless transport system, STELLA Kunststofftechnik, Kastellaun.

SECRO PP28 screw caps with originality ring from STELLA Kunststofftechnik GmbH.

Gabriele Hopf is Head of the Marketing Department at WITTMANN BATTENFELD in Kottlingbrunn, Lower Austria.

WITTMANN R8.2: The new standard in robot controls

Since its market introduction 2009 the WITTMANN Robot R8 control has excelled by way of its trend-setting design, ease of use and intuitiveness. Just in time for K 2010 the performance spectrum has been significantly increased, whereby WITTMANN offers and makes available many of these performance enhancing functions at no extra cost.

Martin Stammhammer

From the beginning developments of the R8 control, the goal of WITTMANN was to develop and intuitive platform while maintaining user simplicity when performing complicated operations and sequences. This approach was imperative during the development work on the R8.2 robot control, as it provides users an expansion of control functions, including additional routines and simplified programming commands. Following are some new functions of the R8.2 control, which are being presented in detail for the first time.

A simplified machine-interface: The view of the SmartStart functions on the teach-pendant screen.

SmartStart

After having completely refurbished the connection between machine and robot, the *SmartStart* function allows the robot to independently switch to automatic mode. This is leading to several advantages. Thus the robot for now is staying in the automatic mode when the machine is switching to the manual mode. Only when the status of the machine is not meeting the demands of the program – and a reasonable continuation of the programming work is not possible – the robot is switching to a save halt. Opening the machine's safety door in the meantime – and thus interrupting the safety circuit – is possible without any problems. The robot is automatically restarting its run without the need of any initiative once the machine has been switched back to the automatic mode.

QuickEdit: The new function provides templates for the simplest "teach-in" of numeric positions, velocities, counters and timers for less experienced users.

The *SmartStart* Function features a simplified start option. With the touch of one button, the R8 controlled robot will perform a dry cycle without the participation of the machine or a single production cycle. A step through cycle mode that has existed for previous software generations is still available. With every *SmartStart* mode several safety features are running in the background, e.g. *FlexSafe* (Flexible Safety Areas) and *Automatic Collision Detection (ACD)*, in manual and step mode.

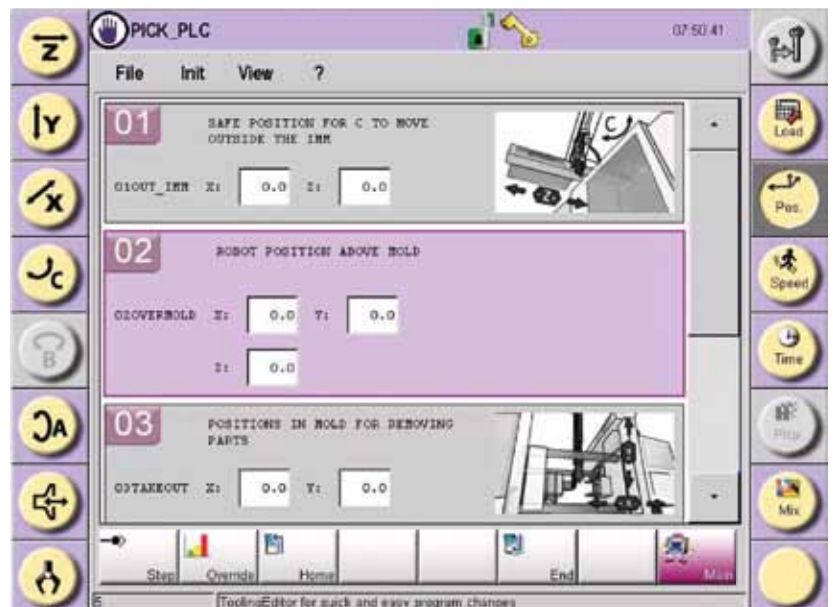

Automatic Collision Detection (ACD)

To provide increased safety for molding machine, robot and peripheral equipment, particularly during the robot programming, all robots equipped with the R8.2 control system will feature the *ACD* function. *ACD* ensures that during the manual programming and test phase of the robot that

the mechanical components are protected. This is achieved through monitoring motor torque levels while speeds are less than 250 mm/s. Should an unexpected increase of torque be detected, the robot stops, which serves for the protection of robot, end-of-arm tooling, machine and mold.

QuickEdit

The concept for the development of the *QuickEdit* function, is to allow an operator to quickly create a new operating program, based on stored programming templates. With *QuickEdit*, setting of the main predefined data for the robot sequence can be done in a few simple steps, by using

program code while just highlight important functions to be modified after a mold change. To provide further security, the functions *ACD* and *FlexSafe* are active in the background. The operator also has the ability to create user specific templates for *QuickEdit* function. WITTMANN's Text Editor remains available for those wishing to complete more complex CNC freely programmable operations.

SmartVacuum

Often with older models of injection molding machines, the problem occurs that the mold drifts during the opening stroke with position fluctuations at the full mold open

position. This can cause issues with the robot and end of arm tool to capture the part or runner during the removal process. WITTMANN has tackled this problem and has created *SmartVacuum*.

By using the *SmartVacuum* function, mold and part can be reliably and repeatedly found. The motion of the kick-stroke is controlled through the use of analog vacuum generators and monitors. As soon as a freely programmable vacuum setting is reached, the forward motion of the robot will be stopped and the part captured. With the servo controlled movable kick-stroke, the probability to damage the part through capturing with too high of pressure or not capturing the part properly, because of being too far away, is eliminated.

FlexSafe function: transparent display of the safety areas.

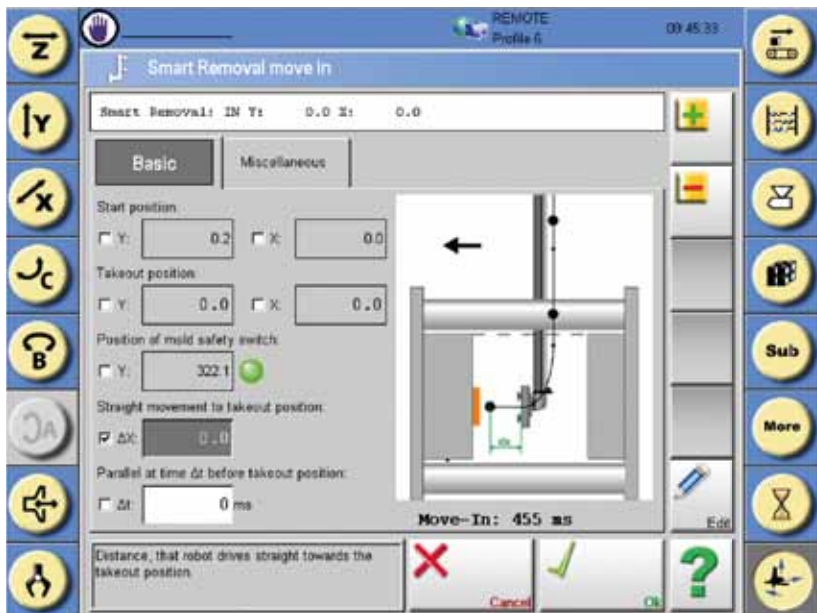
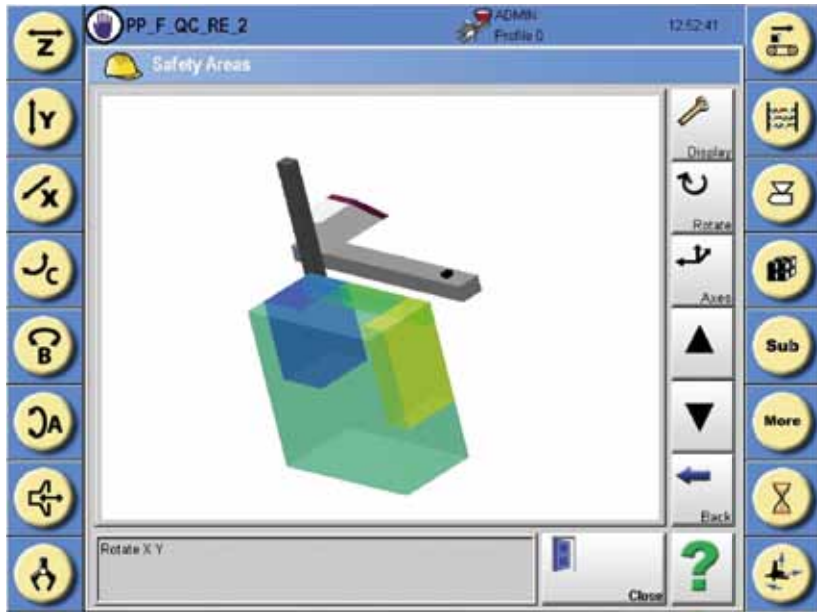

SmartInsertion

Whatever *SmartVacuum* provides for the part removal, *SmartInsertion* does for insertions. Based on the *ACD* function which is active in Teach-Mode, WITTMANN succeeded to integrate torque control into the automatic mode for critical insert motions.

SmartInsertion supports the user with the possibility to variably adjust the insertion force, which protects the cavity and insert in fully automatic mode.

Should the insertion force exceed the defined values, the insert motion will be immediately stopped. This limit values can be set depending on the application and stored with the respective program.

View of the *SmartRemoval* screen.

pictures or animations. These images will step the user through the programming sequence explaining step by step the robots operation.

This type of programming can be used either for the creation of a simple "pick and place" sequences or more complex operations with part removal, degating, sprue disposal and part placement. It is also available to hide unnecessary

These new described control functions together with the already known functions – e.g. *AnalogVacuum*, *TruePath* (parallel motion of up to 12 axes), *FlexSafe* (defined 3D-Safety areas) and *SmartRemoval* (optimized removal cycle for the reduction of removal times of up to 15 %) – provide a solid basis for the new WITTMANN robot control generation R8.2. ♦

Martin Stammhammer is Sales Manager for Robots and Automation Systems at WITTMANN Kunststoffgeräte GmbH in Vienna, Austria.

The new temperature controller generation with touch screen control: TEMPRO plus D

The brand new WITTMANN temperature controller series, TEMPRO plus D, will be presented at K 2010 to the general public for the first time. The TEMPRO plus D embodies additional developments from the already successful TEMPRO plus C series. As a unique enhancement, the new plus series has a color touch screen control providing a superior user interface.

Gerald Schodl

The new TEMPRO plus D series employs a pressure free fluid tank for the 90°C model, while the pressurized heating and cooling chamber units are available for temperature ranges of 140°C, 160°C up to even 180°C. Several versions of the new TEMPRO plus D model are offered in either single zone as well as dual zone configurations to meet the varying demands of the users.

The view of the touch screen shows the operating mode of the zones. It is also the starting point for the selection of the various functions.

From the C-Series to the D-Series

The new WITTMANN TEMPRO plus D temperature controller with touch screen interface. It is available as either a single-zone or as a dual-zone unit.

Only three years ago the introduction of the WITTMANN TEMPRO plus C, was seen as the most technically advanced temperature controller on the market, with multiple standard features that were previously never available. The TEMPRO plus C series was quickly embraced by the global molding community, making it an industry leader. In addition to the new technology available and user friendly interface, esthetics we also improved by way of a compact design and color control display. Through the WITTMANN philosophy of continuous innovation and investment, groundbreaking developments of the TEMPRO plus D are described below.



The touch screen

The 6" color TFT display coupled with a resolution of 640 x 480 pixels, creates a clear and sharp image with an increase of 60% viewing area over previous models.

Operating on a Windows™ CE platform, the control system also provides the ultimate in user simplicity.

Vertically arranged menu buttons on the display and the horizontal direct function buttons fade out automatically after a selectable waiting time, thereby maximizing the size of the main processing data fields to be displayed.

The display can be configured, based on an operator's preference, to display various process parameters. As an example a user may choose from several parameters to monitor such as set-temperature, process pressure, pump pressure, system pressure, water flow in liters/gallons per minute, external temperature, return line temperature, ... The direct function buttons can equally assume special functions based on the particular application, including crash cooling, purging,



leak stop, exchange of fluid, statistical data, ... Operating status is easily viewed with the use of the uniformly understood status colors of green (within tolerance), red (high temperature out of tolerance) and blue (low temperature out of tolerance).

Optimized cycle times and optimization of the medium

The heat exchanger (cylinder tube, cooling coil and heater) of the pressurized temperature controllers only contains a volume of 3 liters. The small fluid volume guarantees an optimized heat-up and cool-down phases, leading to the quickest reaction times and shortest cycle times. No float is needed to monitor fluid level as the pump and system pressure sensors provide continuous feedback for closed loop fluid level control. Information from the pressure sensors is used, to maintain the internal system pressure at least 1 bar above the steam pressure curve, thus avoiding cavitation of the pump.

Process safety with pressure and flow measurement

The measurement of the process and system pressure is standard in all TEMPRO plus D models. From these pressure values the actual pump pressure is calculated and can be shown on the display.

As an option, ultrasonic flow measurement is available. The ultrasonic transmitters and readers capture data based on time, first monitoring in the direction of the fluid flow. Secondly the same measurement is made in the opposite direction. From the difference of the two measurements, and under consideration of a signal curve

in the temperature range of 0–160°C, the velocity of the fluid is calculated. With a final calculation of the velocity bad corresponding pipe diameter, an accurate calculation on water flow can be derived. This value is calculated every two seconds and an accuracy within 5%. These sensors are absolutely maintenance free, as no moving parts are in use in the measuring path.

Reliability and continuity in the process

The D series achieves a temperature precision of $\pm 0.2^\circ\text{C}$. The powerful control and low system fluid volume guarantees shortest reaction intervals during the heating and cooling phases. Because of the practically unlimited life time of the used solid state relays the heater can be switched on and off virtually an unlimited amount of times. The pressurized models come standard with unlimited mold purging design, never overfilling the tank by directing the fluid through a valve in the return water line.

TEMPRO plus for every application

The new TEMPRO plus D excels solely on its standard equipment model offerings. Various options enable the configuration for almost any possible application.

For instance the plus D series can be equipped with multiple heating, cooling valves/ coils and pump sizes, allowing WITTMANN to supply the optimum temperature controller for every application, reaching highest process safety and operation. For a seamless direct communication with the molding machine various serial interfaces (20mA, RS232, RS485, CAN-BUS or SPI) can be selected. ♦

During the phase of heating up the mold symbol appears blue.

The touch screen shows the following operating condition: The actual temperature (displayed in the left screen half – in this case 80°C) which matches with the pre selected set-value. According to the also preset tolerance the mold symbol is green.

When exceeding the set temperature, the mold symbol appears red.

Gerald Schodl is Sales Director of the temperature control technology department at WITTMANN Kunststoffgeräte GmbH in Vienna.



PLASTIPAK Inc. Canada: The versatility of quadrangular design

This fall the Canadian injection molder PLASTIPAK is releasing a new line of innovative plastics packaging for the North American market. These new plastics containers are manufactured using the In-Mold Labeling technology, and they are different in shape. – Learn about how the installation of the new production system was executed – consulting specialists on both sides of the Atlantic Ocean.

Jérôme Empereur

The occasion of the NPE 2009 plastics trade fair has led to a serious contact between the Quebec based PLASTIPAK Company and WITTMANN Canada (that was represented by Rob Miller and Christian Weiss and their Quebec province ANPLAST agent, Stefan Tremblay).

The latest trend in plastics containers

View of the finished automated in-mold labeling work cell.



Specifications of one of the molded parts:

- Volumetric capacity 500 ml
- Material Polypropylene

Presently, the efforts of WITTMANN are supporting and enforcing a major trend in the packaging products market replacing to a large extent the round shapes of containers by quadrangular package design that is offering numerous advantages. For a start the quadrangular shape is offering the possibility to make the optimal use of the existing space when transporting the goods and this of course is leading to lower costs.

Furthermore the labeled surface of an angular package is meeting the demands of comprehensive marketing to a higher degree than a round package ever could. Above all, modern IML technology is providing the opportunity to cover the base surface and the four side wall surfaces using only one single cross label – and this can be done in also only one work step.

This kind of container design has already widely spread in Europe, in total opposition to the circumstances on the North American market. Already at the starting point of their IML project, PLASTIPAK had made the decision to apply the in-mold labeling technology for the production of their product lines. For both product lines different labels are available: either covering three sides of the container,



or five sides, or covering five sides using an overlapping label. The last-mentioned solution – the overlapping label illustrating five sides – is covering the container surface nearly completely, that is to say to a degree of 99%. When using novel “barrier” labels that are protecting the content from oxygen and irradiation of ultra violet light, the best possible conservation of the enclosed food is guaranteed for the ultimate consumer.

From prototype to production system

It has been clear for PLASTIPAK when initiating this project first to order a somehow smaller prototype of this production system – furnished with only one cavity and an

automation that was a bit simplified – to have the opportunity to closely examine the planned product and its labels before starting the real production.

Only seven weeks later, the BATTENFELD injection molding machine of the WITTMANN testing facility in Chassal, France, produced the first sample of the new containers. On location, PLASTIPAK gave their approval of the prototype, and thus the work on the mold and the robot solution for the serial production could start.

For PLASTIPAK, the flexibility and versatility of the system were of central importance, not least from the viewpoint of cost optimization.



Mold and automation

The mold design was developed in constant and close collaboration with the PLASTIPAK specialists in Cookshire, Quebec. Regarding the automation that should be applied, the most important criterion once more was the highest possible flexibility of the system. Thus it was no surprise that PLASTIPAK turned their attention especially to the new WITTMANN W737 FLEX, technology at its best with an unrestricted adaptability to all types of mold and labels. Concerning the W737 FLEX robot, WITTMANN is taking pride in the fact to be able to offer an especially innovative solution for the drive mechanism: two motors that are driving the same axis, mounted at its respective ends, working in perfect synchronicity.

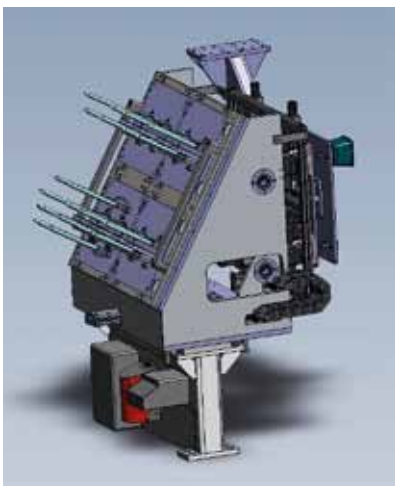

nism: two motors that are driving the same axis, mounted at its respective ends, working in perfect synchronicity.

Installation and service

The delivery and the installation of the finished IML system at PLASTIPAK in Cookshire was accompanied and supervised by the qualified WITTMANN Canada and

ANPLAST teams. A WITTMANN France technician eventually carried out the fine-tuning adjustment and the optimization of the entire production cell.

The preparatory training of the PLASTIPAK personnel and the technical service in the future was again handed over to the Canadian teams.

If nothing else, the high technical level of the PLASTIPAK employees in Cookshire is to be emphasized here, who had an essential stake in realizing this demanding project – in particular Technical Manager Marc-Eric Thibault, Project Manager David Caille, and Plant Manager Sylvain Labrie.

Besides many more already realized projects, also this one is showing quite plainly that WITTMANN is offering at any one time a complete package in the field of automated IML production systems.

This of course is happening in closest cooperation with their clients, leading to absolutely customized solutions even in regard to the required flexibility – and at worldwide availability. ♦



PLASTIPAK plant, Quebec, Canada.

PLASTIPAK Industries Inc. is a privately owned Canadian company. Technically up to date, PLASTIPAK is succeeding in the manufacturing and decoration of rigid thin-walled plastics packaging. With their experience of more than 40 years in the development and production of high-class products, PLASTIPAK is a pioneer in the field of food containers, and it is well-known and highly respected as a manufacturer of value adding products

The company's headquarters are located in Boucherville, Quebec. Owing three production plants, PLASTIPAK is strategically present in the Quebec Province, but also in Ontario, and in Saskatchewan. The company can count on 400 dynamic employees.

PLASTIPAK's business culture is emphasizing the importance of the company staff, therefore the employees are standing in the foreground. The personnel's skill enhancement is seen as one of the most significant factors of success. No work and no responsibility could be urgent enough not to execute everything under consideration of extensive safety precautions. Health and safety at work are a constant concern.

This manufacturer is offering a complete range of light, economic and durable containers that are produced by using injection molding and thermoforming technologies – but also comprehensive decoration solutions. In the first line, the company's products are meant for the food processing industry (including dairy products). The containers and the respective lids are made from polypropylene (PP) and polyethylene (PE) that can be recycled at 100%. PLASTIPAK is committed to reducing the size of their ecological footprint on every level of the company.

The engineers and service technicians are well grounded in the American and European filling and packaging systems. They are working in close collaboration with their clients in order to find the most efficient solution, and to further improve and update their filling systems.

The expertise of the PLASTIPAK service technicians is based on the company's vast years of experience in different fields. The technical team is offering its clients a comprehensive service, accompanying them from the first concept to the finished product.

The mold construction is allowing for a quick change-over. The setup of different shapes/dimensions is made possible directly on the injection molding machine without the need of having to demount the mold frame from the platen.

Picture below: Label magazine for cross labels. These labels can cover all five sides of an open rectangular plastics container. On the left side the drawing is showing the label gripper. It picks up the individualized labels and inserts them into the cavity. The special construction of the magazine is allowing for charging it without shutting down the system. In this particular case WITTMANN delivered four sets of label cassettes, each set consisting of four cassettes, which means one complete set for each type of labels (three types for the container itself, one for the lid).

Jérôme Empereur is Packaging Product Manager at WITTMANN BATTENFELD France SAS. He would like to thank PLASTIPAK for the cooperation making possible this account.

The widening of the WITTMANN Primus series: FEEDMAX Primus material conveyor

The very successful Primus series of plastics processing units is part of every WITTMANN product line. Just to mention temperature controllers, IML systems, and granulators. At K 2010 WITTMANN will present a new conveying unit within the scope of the Primus series.

Markus Wolfram

FEEDMAX Primus is a single conveying unit. It is combining rugged construction, easy maintenance, highest process security, and ease of use. All parts that are getting in contact with the material are made of stainless steel; therefore the unit is perfectly suitable for abrasive applications. The conveying capacity is 120 kg/h max. – this is achieved by using a 1.1 kW motor. The easy to maintain collector motor is mounted directly to the FEEDMAX – and it is equipped with a sound protection hood.

Perfect filter system

To achieve a longer lifetime a needle punched felt filter was used. The sealed filter surface is ensuring that any intake and accumulation of dust particles is made impossible. This filter is never losing its shape, and it is held in position during the entire conveying cycle, ensuring an absolutely unproblematic buildup of vacuum. In addition the filter is equipped with a special seal, thus ensuring a conveying process without leakage. A seal is even used at the discharge valve respectively the shuttle valve. This seal is not positioned directly in the material flow path, thus allowing for an all around sealed system. The setting of the discharge valve is sensor-detected. By this the demand of plastics resin is determined.

Views of the new FEEDMAX Primus with closed (above) and open discharge valve.

Markus Wolfram is responsible for the sales of material handling systems in Austria for WITTMANN Kunststoffgeräte GmbH in Vienna.

Simple parameter display

To simplify the handling of the conveyor, no special display (and therefore no voluminous menu navigation) has been executed.

The conveying time is the most important process parameter. This value can be easily detected by using a potentiometer and then be adapted as necessary.

The operating status of the FEEDMAX Primus can be identified at some distance because of two integrated status lamps – for the first time also the activity of the discharge valve is displayed.

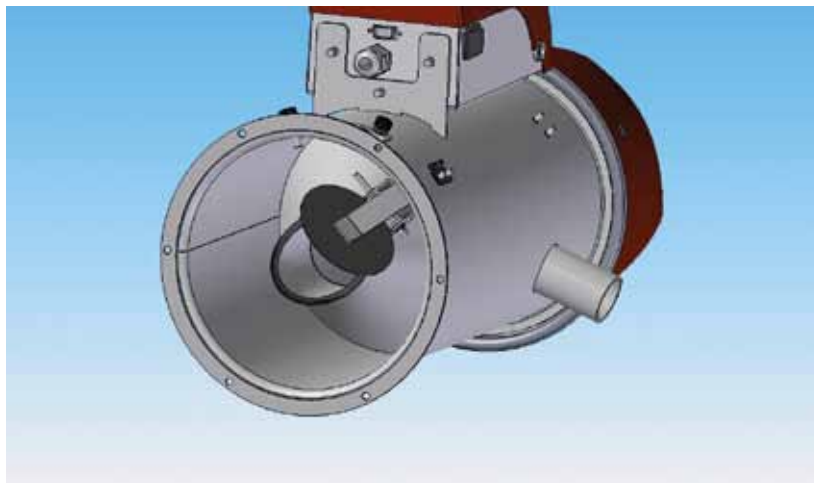
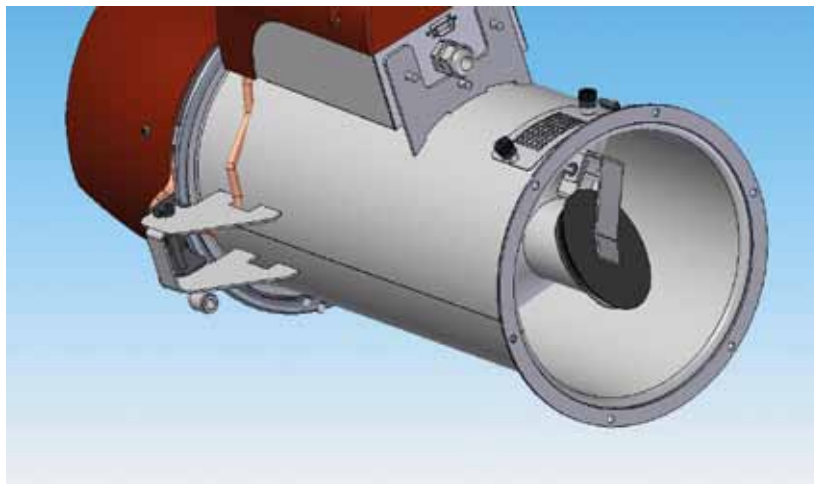

Simple cleaning

Like the other models, this WITTMANN material conveyor is to open easily without using any tool by tripping its self-locking toggle latches – thus reducing maintenance times considerably.

The interior of the stainless steel section is showing no disturbing contours, guaranteeing no dead spots that could cause material hang-up.

Application and advantages

The FEEDMAX Primus conveyor can be used for the

charging of mobile containers and drying hoppers, but also for charging injection molding machines. And even in combination with a volumetric color dosing unit, the FEEDMAX Primus is not lowering its reliability. The sealed shuttle valve is preventing low pressure within the dosing unit.

This means that unregulated adding of any material or coloring additives is practically impossible. Hence the use of the FEEDMAX Primus is leading to a constant and cost-optimized production. ♦

The sales team of the WITTMANN Group



A photo – taken in course of a global Sales Meeting in the spring of 2010 – which displays the impossibility to individually present every single country organization and especially team members: the worldwide active sales team of the WITTMANN Group, perfectly prepared for this year's K in Düsseldorf.

Usually the K show offers its visitors the obvious impression of the “melting pot of nations”. Technical experts, users and manufacturers convene from all directions for eight days in Düsseldorf, including guests from countries which are not necessarily known for being big industrial nations. The conversations taking place here, the international exchange of experience and the purchasing decisions being made, represent progress which cannot be underestimated for the growth of the global plastics industry in the years to come. Despite other new heavyweight exhibitions around the world, the position of the K remains as the worldwide leading fair for the plastics industry and will remain unbroken for many years to come.

Worldwide presence

Not less international than the K and their visitors will be the global sales team of the WITTMANN Group,

whereby both WITTMANN and WITTMANN BATTENFELD will bring together their overall worldwide market knowledge in Düsseldorf. For guests and visitors this is a once every three year opportunity to learn of both the optimum technical advice and support in respect to their local markets, no matter their location.

Locally active

With over 150 technical and sales staff in attendance from the WITTMANN Group, the level of global support will be mostly unmatched at the fair. WITTMANN BATTENFELD Germany, as the hosting country, will provide the largest and most versatile team in attendance. As a big portion of the show visitors are from Germany itself, where they will take the opportunity to meet with experts in several disciplines at one time to develop and design the parts, products and systems of the future.

This is not much different for all European and North American countries which are sending competent teams to both exhibits of the WITTMANN Group. The real touch of internationality will be felt with the global team and representatives arriving from the various locations including Argentina, Australia, Brazil, India, Singapore, South Africa, South Korea and many more countries.

The largest group of product and application technical experts will be arriving from the headquarters in Austria, which has its roots in the historical structure of the WITTMANN Group. The development activity is a large part of the responsibility for staff in Vienna and Kottlingbrunn, where the abilities of WITTMANN and WITTMANN BATTENFELD are best brought together. The specialists from Austria are available with their product knowledge in case of very complex and non-standard questions, requiring a detailed insight into the products. ♦



Wittmann Robot Systeme GmbH
Am Gewerbepark 1-3
D-64823 Groß Umstadt

Battenfeld
Wittmann Battenfeld GmbH
Werner-Battenfeld-Straße 1
D-58540 Meinerzhagen

**WITTMANN
KUNSTSTOFFGERÄTE GMBH**
1220 Vienna, AUSTRIA
Lichtblaustrasse 10
tel.: +43-1 250 39-0
fax: +43-1 259 71-70
info.at@wittmann-group.com
www.wittmann-group.com

**WITTMANN
BATTENFELD INC.**
1 Technology Park Drive
Torrington, CT 06790, USA
tel.: +1-860 496 9603
fax: +1-860 482 2069
info.us@wittmann-group.com
www.wittmann-group.com

**WITTMANN ROBOT
(KUNSHAN) CO. LTD.**
No. 1 Wittmann Rd.
DianShanHu Town
Kunshan City, Jiangsu Province
215245 CHINA
tel.: +86(0) 512 5748 3388
fax: +86(0) 512 5749 3199
info@wittmann-group.cn
www.wittmann-group.com

**WITTMANN
BATTENFELD GMBH**
Wiener Neustädter Strasse 81
2542 Kottlingbrunn, AUSTRIA
Tel : +43 (0)2252 404-0
Fax: +43 (0)2252 404-1062
info@wittmann-group.com
www.wittmann-group.com

Wittmann

Wittmann Battenfeld

