

# Water Flow Regulators



*The Leading Water Flow Regulator Worldwide*  
Technology working for you.

**Wittmann**

Progress through Innovation

# The Advantages of our Water Flow Regulators

EPDM O-ring seals are heat and water resistant.

Our sight tube is polyamide 12 which is superior, compared to competitor's polycarbonate, when higher temperature water is used. Competitors charge extra for the better material. On our unit it is standard.

Reference marks are molded in, not painted on.

Enlarged water passages minimize flow restrictions, deliver increased flow volume through the molds and enhance heat transfer performance. In fact, pressure drop from our regulators is about half that of competitive units. That's an important difference if plant water pressure is low.

Wittmann Flow Regulators include precision, threaded brass inserts (Series 301) or brass sockets (Series 101) for your water hose connections, unlike poorly designed regulators which use leak-prone molded threads which can strip easily.

Housings molded of reinforced polyphenylene oxide for tough industrial use.

All units are 100% leak tested before shipping.

Thermometer is located directly in the water flow giving a more precise reading and a quicker reaction to changes. Competitor's thermometers are not in the water flow path.

Competitor's regulators include a large diameter valve for the main seat which means regulation is not precise. With a very small movement of the handwheel, the valve is opened almost completely. Our units have a smaller diameter seat which allows better adjustment of flow.

Using brass valves and brass connections is resulting in highest corrosion resistance.



## — Option: Dry-Out Valve

Allows complete clean out of regulator sight glasses.



## — Easier to Clean

The water flow regulators are exceptionally easy to clean. A top access cap is simply removed and a brush (provided) quickly cleans the tubes without removing them.

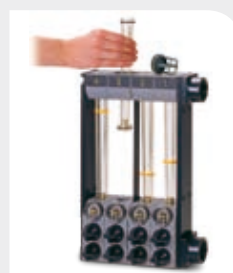

## — Easier to Remove

Individual sight tubes can be easily removed and resealed, if necessary. Precision O-rings positively seal the sight glass, absolutely leakproof even under maximum loads.

## Series 101 Flow Rate 0 – 10 l/min per circuit

The essential device for your plastics processing machines for open and closed cooling circuits. Flow volume is indicated in accordance with the float measuring principle: a cone is lifted by the water flowing in the return of the mold circuit.

### Technical Data:

- Flow range per circuit: Standard 0 – 10 l/min. On request: AI, PVC-cones.
- Standard: Mold connections with 12 mm brass socket for 3/8" hoses.  
On request: Threaded connection with G 3/8" brass threaded sleeve with screwed 14 mm brass socket for 1/2" hose, or screwed 20 mm brass socket for 3/4" hose

### Order data for standard model with thermometer:

Circuits	Order No.
1-zone	DF01TA0000
2-zone	DF02TA0000
4-zone	DF04TA0000
6-zone	DF06TA0000
8-zone	DF08TA0000
10-zone	DF10TA0000
12-zone	DF12TA0000



## Series 301 Flow Rate 0 – 30 l/min per circuit

The optimum flow regulator for large injection molding and blow molding machines. Its low pressure drop makes it suitable for highest flow volumes. However, by means of a special design of the regulating valves, excellent regulation and accurate reproduction of cooling water volume and temperature in the different mold circuits can also be achieved for low flow volumes.

### Technical data:

- Flow range per circuit: Standard 0 – 30 l/min. On request: AI, PVC-cones.
- Standard: Mold connections with G 3/8" brass threaded sleeve  
On request: with screwed 14 mm brass socket for 1/2" hose, or screwed 20 mm brass socket for 3/4" hose



### Order data for standard model with thermometer:

Circuits	Order No.	Circuits	A	Press.	Temp.
			mm	max.	max.
1-zone	DR01TB0000	1-zone	72	10 bar	40 °C
2-zone	DR02TB0000	2-zone	124	8 bar	60 °C
4-zone	DR04TB0000	4-zone	229	6 bar	80 °C
6-zone	DR06TB0000	6-zone	334	4 bar	100 °C
8-zone	DR08TB0000	8-zone	439		
10-zone	DR10TB0000	10-zone	543		
12-zone	DR12TB0000	12-zone	647		

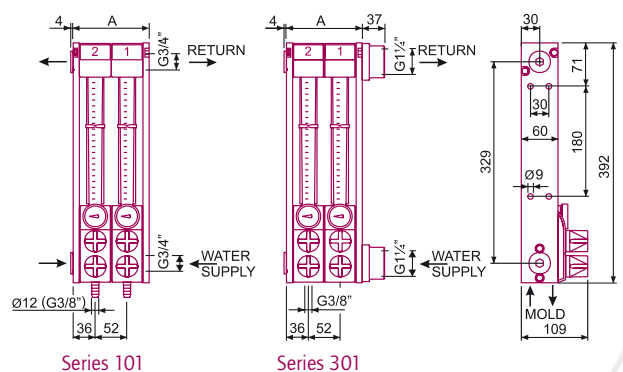

# Series 200/230 Brass Water Flow Regulator

The upper and lower blocks as well as the manifolds are made of brass for high temperatures and pressures.

— **Technical data:**

- Temperature max. 100 °C
- Pressure max. 16 bar.
- Flow range per circuit:
  - Series 200 0 – 10 l/min
  - Series 230 0 – 30 l/min
- On request: AI, PVC-cones.
- Standard: Mold connections with G 3/8" brass threaded sleeve.
- On request: with screwed 14 mm brass socket for 1/2" hose, or screwed 20 mm brass socket for 3/4" hose



Order data for standard model with thermometer:

Circuits	Order No.	
	Series 200	Series 230
2-zone	DH02TB0000	DQ02TB0000
4-zone	DH04TB0000	DQ04TB0000
6-zone	DH06TB0000	DQ06TB0000
8-zone	DH08TB0000	DQ08TB0000

Series 200/230		Series 200/230	
Press. max.	Temp. max.	Circuits	A mm
16 bar	20 °C	2-zone	140
10 bar	40 °C	4-zone	262
8 bar	60 °C	6-zone	384
6 bar	80 °C	8-zone	506
4 bar	100 °C		

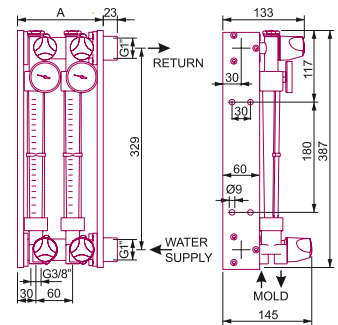

# Series 401 Flow Rate 0 – 8 l/min per circuit

The ideal unit specially designed for the smaller range of injection molding machines up to approx. 80 tons clamping force.

— **Technical data:**

- Flow range per circuit: Standard 0 – 8 l/min. On request: AI, PVC-cones.
- Standard: Mold connections with 12 mm brass socket for 3/8" hose



Order data for standard model with thermometer:

Circuits	Order No.	Series 401		Series 401	
		Press. max.	Temp. max.	Circuits	A mm
2-zone	DD02TA0000	10 bar	40 °C	2-zone	110
4-zone	DD04TA0000	8 bar	60 °C	4-zone	200
6-zone	DD06TA0000	6 bar	80 °C	6-zone	290
8-zone	DD08TA0000	4 bar	100 °C	8-zone	380

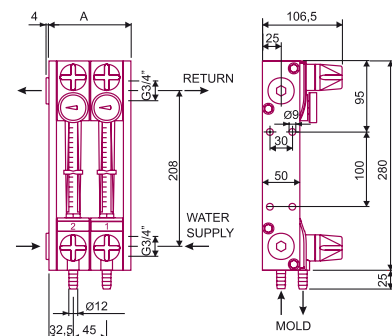

## Optional: Solenoid Valves

The Series **101** and **301** Water Flow Regulators can be supplied with shutdown solenoid valves.

### — **Valve Z:**

Central shutdown of several mold circuits.

Application: e.g. controlled by the cycle of the injection molding machine. When the injection cycle is stopped the cold water flow is shutdown to avoid condensation on the mold cavities.

### — **Valve E:**

Shutdown of cooling water in individual mold circuits.

Application: e.g. chilled cores

The valve can also be controlled by a temperature controller from the injection molding machine for mold temperature control.

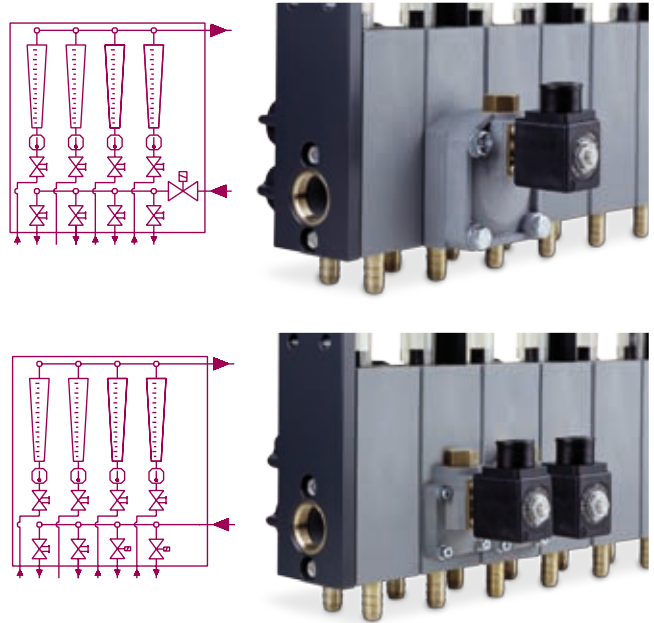

## FLOWCON: Automatic Flow Regulator

### **Accurate Control and Perfect Process Monitoring**

- Precise, stable mold temperature through automatic control
- The development of this unit is based on many years of applied experience
- Microprocessor controlled accuracy  $\pm 1\text{C}^\circ$
- Up to 8 zones can be controlled individually
- Storage of setup data for 7 different molds
- A tolerance window can be set on the display. If the temperature exceeds the tolerance a buzzer or alarm contact is activated.
- Serial interface for data transfer to IMM standard
- Secures the quality of the molding process by perfect temperature control and monitoring
- Plunger type solenoid valves with large seat diameter ensure operation even with poor water quality



# Optimal Product Quality using FLOWCON

## — Mold Temperature Control by FLOWCON

Closed circuits reduce the period for warming up the mold. Continuous control ensures a water flow when cooling is needed and prevents cooling down the mold when production is interrupted.

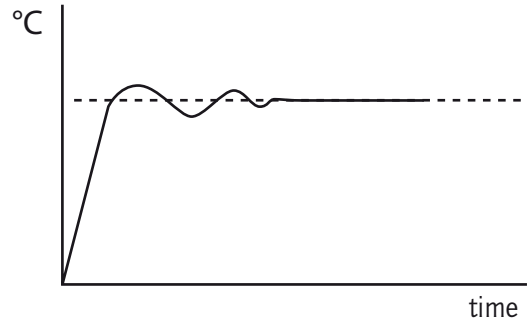

## — Mold Temperature Controlled by Standard Water Flow Regulator

Water flow is adjusted manually until the set value of mold temperature is reached. When production is interrupted or when water pressure is changing the mold temperature will change.

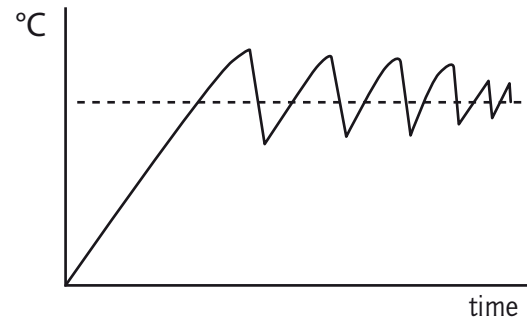

## Simple to Operate

### User Friendly Display

- Green LED shows that valve for the circuit is open RED LED shows that temperature is out of tolerance
- Actual/Set temperature
- Selection of set point, tolerance, slave control of circuits
- Automatic or manual (fixed cycle) mode
- Settings for slave controlled circuits
- Selecting circuits

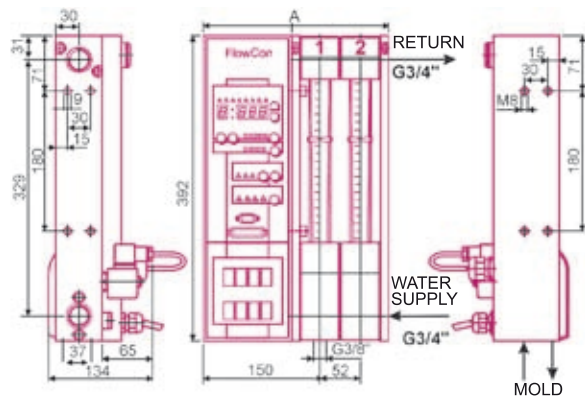

Circuits	A mm	Press. max.	Temp. max.
2-zone	238	10 bar	40 °C
4-zone	343	8 bar	60 °C
6-zone	448	6 bar	80 °C
8-zone	553	4 bar	100 °C

# FLOWCON: Installation of Sensor

## Recommended Position – Directly in the Mold Close to the Cavity

Requirements for zone 1 – 8:  
 Mold sensor FeCo type J,  $\varnothing = 6 \text{ mm}$   
 incl. M10 x 1  
 Cabel = 2000 mm

Order No. D900000542

## Sensor can be Placed in the Return Line of the Individual Circuit

Requirements for zone 1 – 8:  
 Water sensor FeCo type J,  $\varnothing = 1,5 \text{ mm}$ , length = 100 mm  
 Cabel = 2000 mm

Order No. T700000855

Y-connector  
 (incl. screwfitting for the sensor, connection piece fittings  
 G 3/8" and reduction G 3/8" to 1/4")

Order No. D900000550

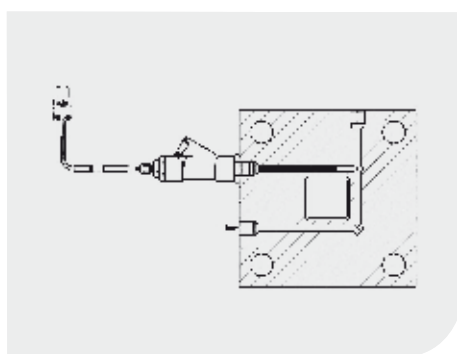
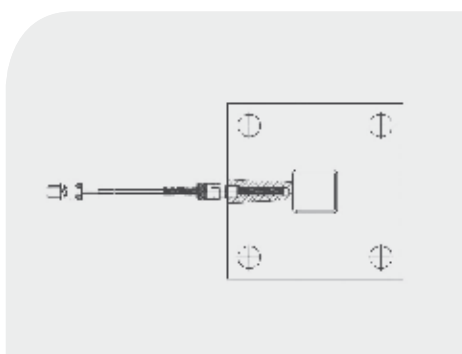

## Sensor in Return Line to Water Flow Regulator

This solution requires a constant flow of water, so the sensor can realize the changes in temperature. The required flow can be selected on the display with a sequence of opening and closing.

Mold circuit sensor:  
 FeCo type J,  $\varnothing = 1,5 \text{ mm}$ , length = 60 mm  
 Cabel = 800 mm  
 incl. sensor screw M8 x 1  
 incl. seal disc teflon  $\varnothing = 1,5 \text{ mm}$   
 incl. reduction G 3/8" – M8 x 1

Order No. D900000741



## FLOWCON Technical Specifications

Water flow	10l/min per circuit
Circuits	up to 8 circuits
Water connector	G 3/8"
Temperature sensor	type J thermocouple
Power supply	230 V/50 Hz, 1 Ph, 1,5 A
Power supply cable	with IEC safety plug
Serial interface	20mA, RS232, RS485
Storage of setup data for 7 different molds	

## Interface Cables

Type	IMM	Order No.
20mA	ENGEL	T500000310
RS232	ENGEL	T500000313
20mA	KRAUSS MAFFEI	T500000604
20mA	FERROMATIK	T500000422
20mA	DEMAG	T500000311
20mA	ARBURG with plug 3-pole	T500000312
20mA	ARBURG with Sub-D-plug 9-pole	T500000930

Cables for other types of IMM on request.



Technology working for you.

**Wittmann Kunststoffgeräte GmbH**

Lichtblaustraße 10

1220 Vienna | Austria

Tel.: +43 1 250 39 0 | Fax: +43 1 259 71 70

[info@wittmann-robot.at](mailto:info@wittmann-robot.at)

[www.wittmann-robot.com](http://www.wittmann-robot.com)